



VIBRATING LEVEL SWITCH

Process measurement



Representantes / Distribuidores Autorizados

 Dastec Uruguay S.R.L.
Tel: (+59 8) 2400 4046
Email: info@dastecsrl.com.uy
Web: www.dastecsrl.com.uy



Representantes / Distribuidores Autorizados

 Dastec S.R.L. Paraguay
Tel: (+595 9) 8310 0799
Email: info@dastecsrl.com.py
Web: www.dastecsrl.com.py

VIBRATING FORK LEVEL SWITCH

VIBRATJ-VD is a universal level switch for use in all liquids. It has a high level accuracy, and can be used either full or empty. The whole design can easily be installed, requires little or no maintenance and offers maximum reliability in a wide application range.

Application area

The Vibrating fork level switch model **VD** is a point level switch for liquid level detection in storage tanks, tanks with agitators, and piping. It can be used as an alternative to float switches as in applications where build-up, turbulence, liquid flow and gas bubbles are present.

Technical Data of VD

Operating Voltage	Autoadaptation 20-35V DC 30-250V AC
Power consumption	1.5W(Max.)
Isolation voltage	1500V(Min.)
Overvoltage protection	CAT III
Output	Relay DPDT (Double pole, Double Throw)
Output capacity	250VAC
Adjustable on delay timer	0-30s
Switching delay	< 0.5s
Electrical connections	M20X1.5
Ambient temperature	-40 to +70°C
Process temperature	-40 to +250°C
Process pressure	0.1~6.3 Mpa
Process fitting	Thread 1/2" or 3/4" BSPT
Material of probe	SUS 304/316L
Measuring range	4 m (max.)
Insertion Length	48 mm
Frequency	1200 Hz
Density of liquid	0.6g/cm ³
Protection class:	IP67

VD series

Vibrating Level Switch For liquids



Electrical connection

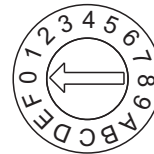
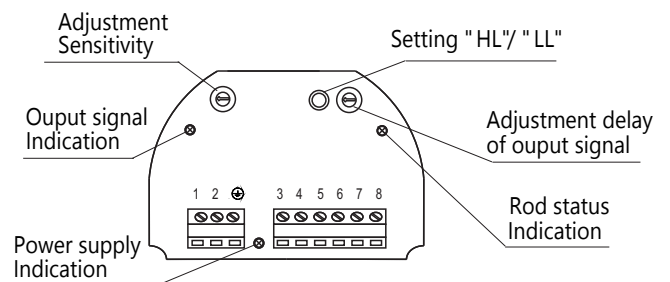

Setting sensitivity class
A to F, or 0 to 8 depending
medium density.

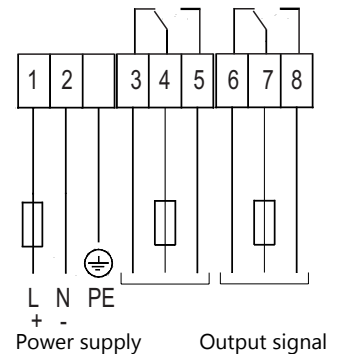

Output Signal Mode

Mode	Probe no covered in medium
HL	<ul style="list-style-type: none"> ⊗ Ouput signal Indication ⊗ Rod status Indication
LL	<ul style="list-style-type: none"> ⊗ Ouput signal Indication ⊗ Rod status Indication

Mode	Probe covered in medium
HL	<ul style="list-style-type: none"> ⊗ Ouput signal Indication ⊗ Rod status Indication
LL	<ul style="list-style-type: none"> ⊗ Ouput signal Indication ⊗ Rod status Indication

Specification Sheet

Dimension

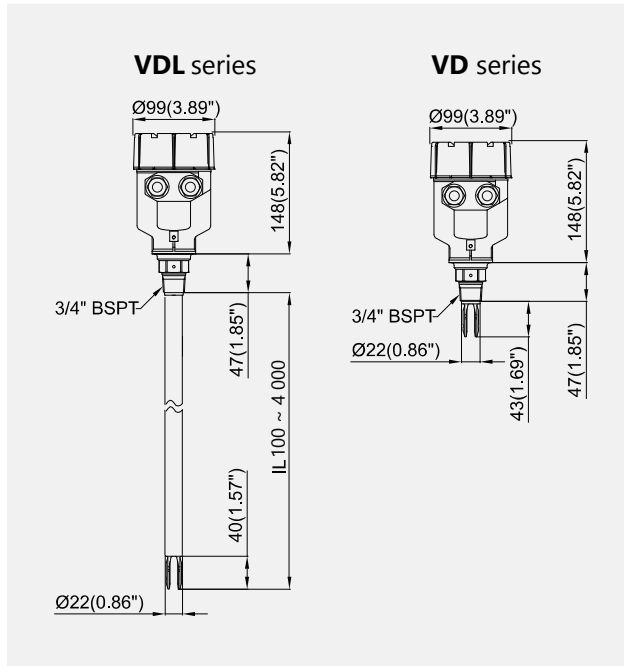

Mode of alarm

In the figure "HL/LL" is button switch for alarm. High mode of alarm (lift up button HL) means that the relay alarms when material is higher than the level working point. Low mode of alarm (press LL button) means that the relay alarms when material is lower than the level switch working point.

Instrument is in the state of alarm when power off - relay is in the state of lose of power

Density setting

In the figure, clockwise rotation of "Sensitivity" gradually increases sensitivity

Delay

" Delay " in the figure is the adjustment knob for delay, the purpose is to make the instrument stable stable output. Clockwise rotation of the knob " Delay " increases the delay time. On the contrary, decreases. Time delay function is effective for the instrument only in the process of transformation from the alarm state to the normal state, that is to say, there is no time delay when instrument outputs alarm signal. In 0.5~30 seconds delay time is adjustable.

How to order

VD - - - - - - - -

01 02 03 04 05 06 07 08

01) Series of Level Switch

VD Standard type
VDL Extended rigid rod series

02) Material of Housing

p Aluminum, not singht hole
PA PA: Aluminum, singht hole
S SUS304, not singht hole
SA SUS304, with singht hole

03) Level Switch Version

Blank General Industrial
EX Dust Explosion-Proof

04) Electrical Connection

M Double M20X1.5
N Double 1/2 NPT

05) Process Connection

B1 1/2' BSPT thread
B2 3/4' BSPT thread
G1 1/2' G Thread
G2 3/4' G Thread
N NPT Thread
F Flange

06) Process Temperature

A -20 to +80°C
T -40 to +150°C
H -40 to +250°C

07) Material of Probe

01 SUS 304
02 SUS 316L

08) Insertion length

Blank Standard, 48 mm
L500 500mm
.....

Indication Light

In the figure "Power" green power indicator light, green light indicates the instrument power supply is working normally; In the figure "Fail" the yellow working indicator light, dark yellow light indicates the instrument is working normally, the fork vibration is normal, bright yellow light indicates the fork stops vibrating; tops vibrating; In the figure "Alarm" red alarm indicator light, bright red light indicates the instrument output is in the state of alarm; On the contrary, alarm is removed when the red light darken.

VIBRATJ

Specification Sheet

Vibrating Fork Level Switch For Liquid

VSTJ Mini series



Technical Data

Material of housing	SUS 304
Protection class	IP65 Connector DIN IP67 Connector M12x1.4pin
Material of probe and thread parts	SUS 316L
Process fitting	VSTJ-40: 1/2," 3/4" or 1" BSPT/G VSTJ-100: 1" BSPT / G Tri-Clamp Flange
Operation Voltage	12-55 VDC
Power consumption	10 mA
Output	PNP / NPN (max.400mA)
Frequency	1200 Hz (VSTJ-40) 304 Hz (VSTJ-100)
Switching delay	< 1.0s
Electrical connections	DIN M12x4 pin
Control indication	Green Power supply Red Switching status
Ambient temperature	-40 +70°C
Process temperature	-40...+150°C
Process pressure	VSTJ-40 -0.1...6.3MPa VSTJ-100 -0.1...2.5MPa
Density of medium	more 0.6g/dm ³
Viscosity of medium	1.0...10 000 cSt
Wetted length	VSTJ-40 48 mm VSTJ-100 106 mm

Description

VSTJ-40 /100 series compact tuning fork level switch, its a point level switch for liquid level detection in storage tanks, tanks with agitators, and piping. It can be used as an alternative to float switches as well as in applications where build-up, turbulence, liquid flow and gas bubbles are present.

Features

- Compact struction design. Low space requirement easy to installation in laces with limited access
- Stainless steel housing, rugged. Probe is SUS 316L
- Switching status, external testing, simple control
- Multi version process fitting
- Process temperature -30...+150°C

DIN wiring

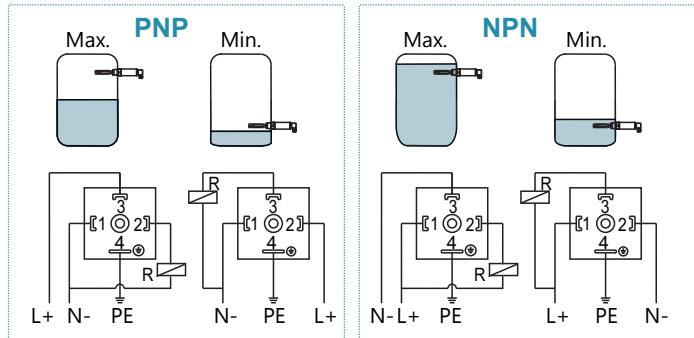

M12x4 pin wiring

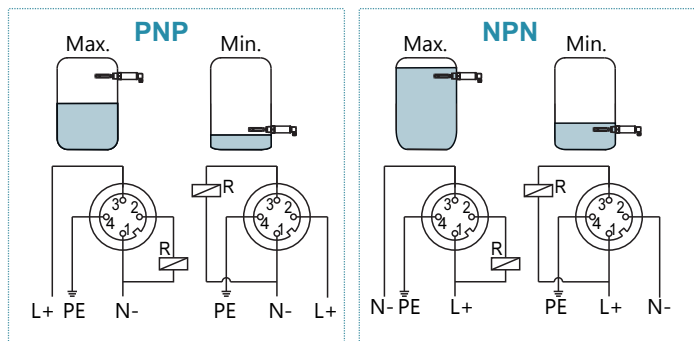

PNP wiring:

High(Max.) Mode:

Pin 1 connects to N-.
Pin 3 connects to L+.
Pin 2 is output, it connects to N- with relay.
Pin 4 connects to tank ground.

Low(Min.)Mode:

Pin 1 connects to N-.
Pin 2 connects to L+
Pin 3 is output, it connects to "N-" with relay.
Pin 4 connects to tank ground.

NPN wiring:

High(Max.) Mode:

Pin 1 connects to L+.
Pin 3 connects to N-.
Pin 2 is output, it connects to N- with relay.
Pin 4 connects to tank ground.

Low(Min.)Mode:

Pin 1 connects to L+.
Pin 2 connects to N-
Pin 3 is output, it connects to "N-" with relay.
Pin 4 connects to tank ground.

How to order

VSTJ - **40** - - - - - -
 01 02 03 04 05 06

01) Type of the Level Switch

- 40 Length of fork is 40 mm
- 100 Length of fork is 100 mm

02) Material of housing

- 1 SUS 304
- 2 SUS 316L

03) Electrical connection

- V DIN 43650 Plug
- M M12x4 pin connector

05) Process temperature

- A -30 to +80°C
- B -30 to +150°C

05) Process fitting

- B1 1/2' BSPT thread
- B2 3/4' BSPT thread
- B3 1' BSPT thread
- G1 1/2' G thread
- G2 3/4' G thread
- G3: 1' G thread
- N Thread NPT
- F Flange
- TC Tri-Clamp

06) Insertion length

- Blank Standard
- L200 200 mm
- ...

Accessories



Welded joint

Use to installation of process sensors in tanks or pipes



01 - Welded joint

$\frac{W}{01} - \frac{PT}{02} - \frac{3/4}{03} - \frac{S}{04}$

- 04 - Material
Bland - Steel 20
S - SUS304
- 03 - Size of thread
1/2 - 1/2" thread
3/4 - 3/4" thread
1 - 1" thread
- 02 - Thread version
PT - PT thread
PF - PF thread



Process Adaptor

For the installation of sensors in tanks or pipes

Internal thread is 3/4" PF
 External thread is 1 1/2" G
 Material of adaptor is SUS 304
 Code of adaptor: PAPF-3/4PF-1 1/2G

Dimension, mm

VSTJ-100 DIN Connector

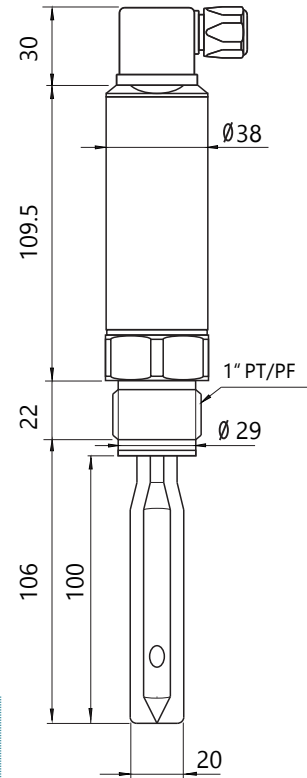

VSTJ-40, 3/4" thread DIN Connector

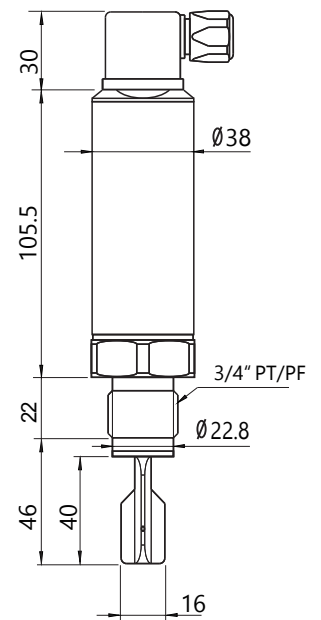

VSTJ-40, 1/2 thread DIN Connector

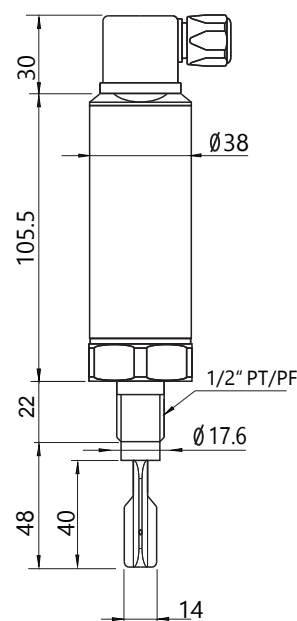

M12x4 pin Connector

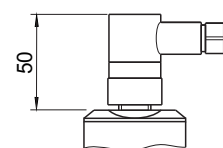

VIBRASH

Specification Sheet

Vibrating Fork Level Switch for Liquid VP series

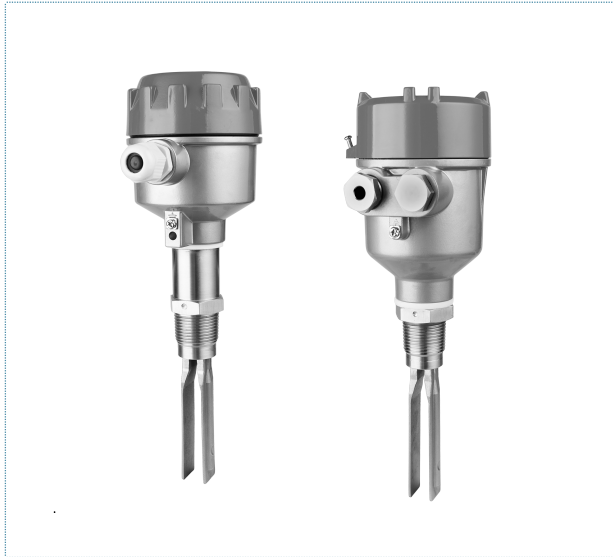

Technical Data of VP series

Material of housing	Aluminum
Protection class	IP65
Material of probe and thread parts	SUS 304
Process fitting	1" BSPT / G
Operation Voltage	24 VAC, 24 VDC 220 VAC, 110 VAC
Power consumption	10 mA
Output signal	DPDT relay 220 VAC, 5A; 30 VDC, 3A
Frequency	355...365Hz
Switching delay	< 1.0s
Electrical connections	M20x1.5
Control indication	Green Power supply Red Switching status
Ambient temperature	-30 to +60°C
Process temperature	-30...+80°C / +150 °C
Process pressure	Max.2.0 MPa
Density of medium	more 0.7g/dm ³
Viscosity of medium	1.0...10 000 cSt
Wetted length	Max. 2000 mm

Principal of Operation

VP version Fork sensors use a mechanical resonance system. The mechanical element is excited and kept in resonance by the sensors electronic circuitry. An electrical signal is applied to a piezoelectric crystal. This electrical excitation causes physical deformation of the crystal, which in-turn creates the probe element vibration at its natural resonant frequency.

When no material is present around the fork, the vibration exists. With material present and surrounding the fork, the vibration is dampened and detected by the electronic circuitry. This results in a change in the relay output and local LED indication.

Principal of Operation

- Power plant, ash silo, ash bunker, reservoir, exhaust gas purification tank, fuel tank, etc.
- Oil field, crude oil or refined oil storage tank, three-phase separator, settling tank, sewage tank and etc.
- Chemical industry, distillation tower, ammonia water tank, toxic liquid tank, etc.
- Cement - Stone tank, cement silo, slag storage silo and etc.
- Water treatment, Food, pharmaceutical, environmental protection, paper and other industries.
- Cement - Stone tank, cement silo, slag storage silo and etc.

Wiring and Electrical connection

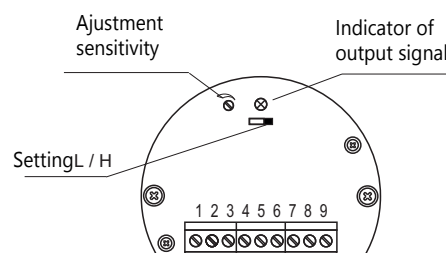
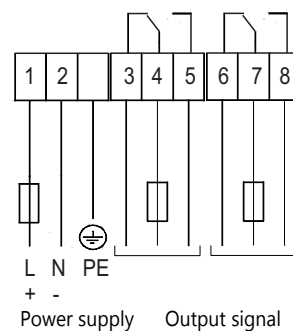

Specification Sheet

How to order

VP - $\frac{S}{01}$ - $\frac{\square}{02}$ - $\frac{\square}{03}$ - $\frac{\square}{04}$ - $\frac{\square}{05}$ - $\frac{\square}{06}$

01) Version of Level Switch

S General industrial
L Extended version
EX Explosion-proof

02) Operating Voltage

A 220 VAC
B 110 VAC
C 24 VAC
D 24 VDC

03) Process Temperature

Blank Standard, -30...+80°C
T High-Temperature, max.+150°C

04) Process Connection

B3 1" BSPT thread
G3 1" G thread
N NPT thread
F Flange
TC Tri-clamp

04) Material of Wetted Parts:

01 SUS304
02 SUS316L

06) Insertion Length

Blank Standard length
L500 500mm
L750 750mm
.....

Dimension, mm

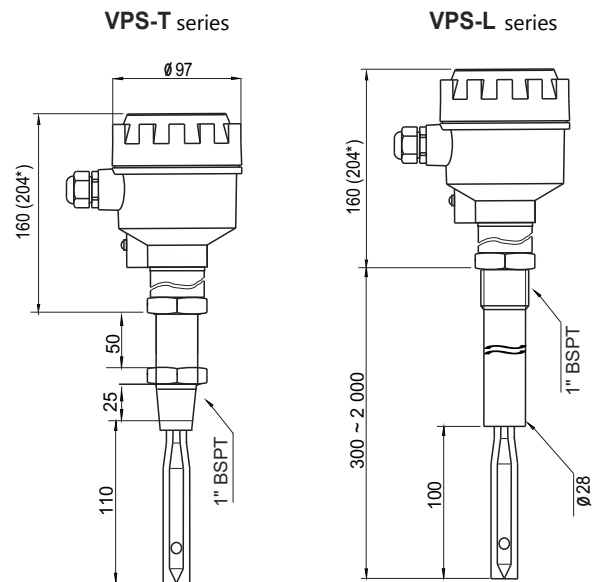
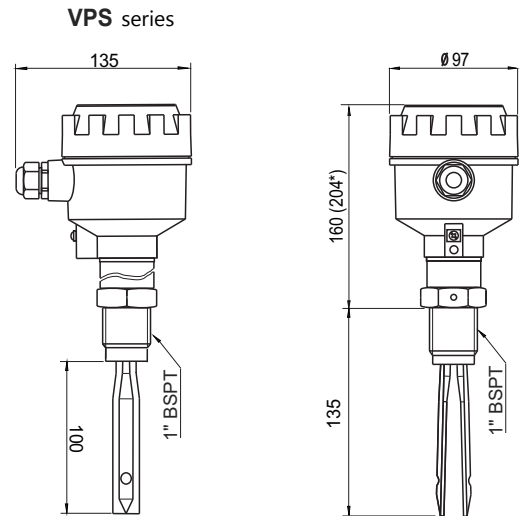

Accessories of process adaptors



Weld-in joint 1" PT/PF

Use to installation of process sensors in tanks or pipes

Code of joint $\left\{ \begin{array}{l} \text{WPT-1 - 1" PT thread, Steel 20.} \\ \text{WPF-1 - 1" PTS thread, Steel SUS304} \end{array} \right.$



Process Adaptor 1" PT/PF

For the installation of VP sensors in tanks or pipes

Internal thread - 1" PT
External thread - 1 1/2" G
Material - SUS 304
Code of adaptor - PAPT-1PT-1 1/2G



Process Adaptor

For the installation of VP-L extended type of sensors in tanks or pipes

Pmax - 6 bar
External thread - 1 1/2" G
Material - SUS 304
Code of adaptor - PAG-1 1/2G

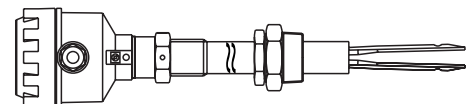

VIBRATJ

Specification Sheet

Vibrating Level Switch for Solid

VA VC VS series



Technical Data of VA VC VS

Operating Voltage	Autoadaption 20-35V DC 30-250V AC
Power consumption	1.5W(Max.)
Isolation voltage	1500V(Min.)
Overvoltage protection	CAT III
Output	Realy DPDT
Output capacity	250VAC, 3A; 30VDC, 1A
Delay time	0-30s adjustable
Switching delay	< 1.0s
Electrical connections	M20X1.5
Ambient temperature	-40 to +70°C
Process temperature	-40°C....250°C -40°C....150°C for VC
Process pressure	-0.1....2.5 MP -0.1..0.6 MPa for VC
Process fitting	Threaded 1 1/2" BSPT (VS thread is 1" BSPT)
Material of probe	SUS 304/316L
Measuring range	Max.4m (cable type 10m.)
Frequency	160 Hz
Density of liquid	0.01 g/cm ³
Protection class	IP67
Material of housing	Aluminum / SUS 304

Description

VA VC VS are level switch for universal use in powders and fine-grained bulk solids. The level switch detects reliably and robust the min. or max. level. The tuning fork is ideal for use either in and abrasive products as well as in bulk solids with very low density.

Features

- Various Process Connections
- No Calibration Required
- Mounting on the top or side of the storage vessel
- Low costs for maintenance through robust design
- Minimum time cost expenditure thanks to simple setup without medium
- Reliable function through product-independent switching point

Mounting and Setting sensitivity

Sensor with thread process:

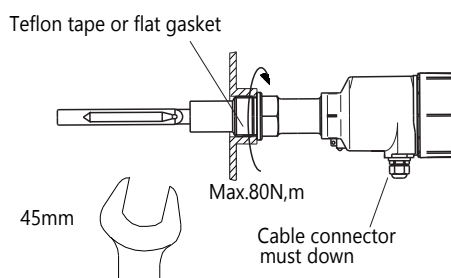

Sensor with flange process:

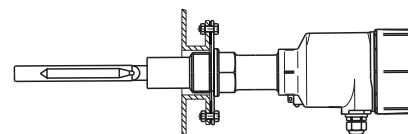

Using gasket to seal

Gasket NBR rubber available to use below 150 °C
Metal or graphite Gasket used more 150 °C
process temperature.

Electrical connection

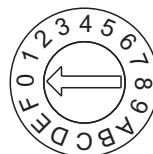

Setting sensitivity class 0 to 7
for bulk density more 20 g/l.

Setting sensitivity class 8 to F
for bulk density less 20 g/l.

Configuration Table

VA(L)/VC/VS(L) - □ - □ - □ - □ - □ - □ - □
 01 02 03 04 05 06 07 08

01) Series of Level Switch

- VA Standard type
- VS Insertion length - 108 mm
- VAL Extended rigid rod
- VC Extended cable

02) Material of Housing

- P Aluminum, not singht hole
- PA Aluminum, singht hole
- S SUS304, not singht hole
- SA SUS304, with singht hole

03) Level Switch Version

- Blank General Industrial
- EX Dust Explosion-Proof

04) Electrical Connection

- M Double M20X1.5
- N Double 1/2 NPT

05) Process Connection

- B3 1' BSPT thread (VS series)
- B4 1 1/2' BSPT thread
- G3 1' G Thread (VS series)
- G4 1 1/2' G Thread
- N NPT
- F Flange

06) Process Temperature

- A -40 to +80°C
- T -40 to +150°C
- H -40 to +250°C

07) Material of Probe

- 01 SUS 304
- 02 SUS 316L

08) Insertion length

- Blank Standard
- L500 500mm
-

Dimension, mm

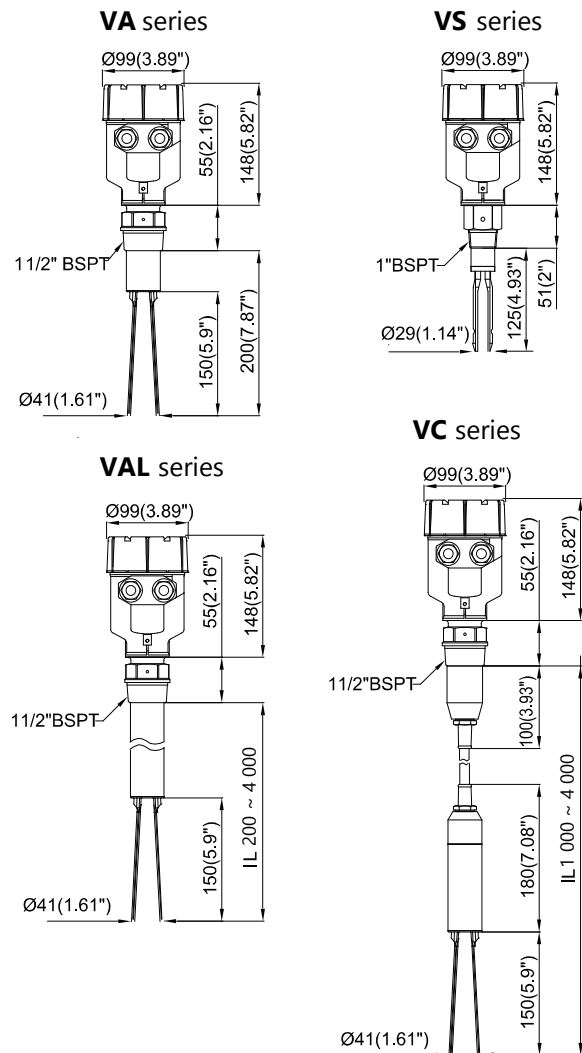

Electrical panel

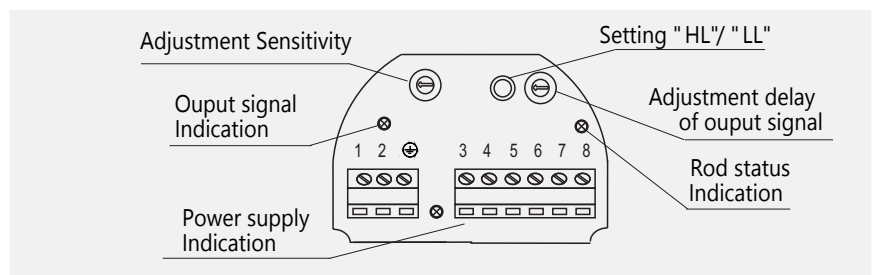

Output Signal Mode

Mode	Probe no covered in medium	Probe covered in medium
HL	<ul style="list-style-type: none"> ⊗ Output signal Indication ⊗ Rod status Indication 	<ul style="list-style-type: none"> ⊗ Output signal Indication ⊗ Rod status Indication
LL	<ul style="list-style-type: none"> ⊗ Output signal Indication ⊗ Rod status Indication 	<ul style="list-style-type: none"> ⊗ Output signal Indication ⊗ Rod status Indication

VIBRATJ

Specification Sheet

Vibrating Rod Level Switch for Solid VF(L), VR series

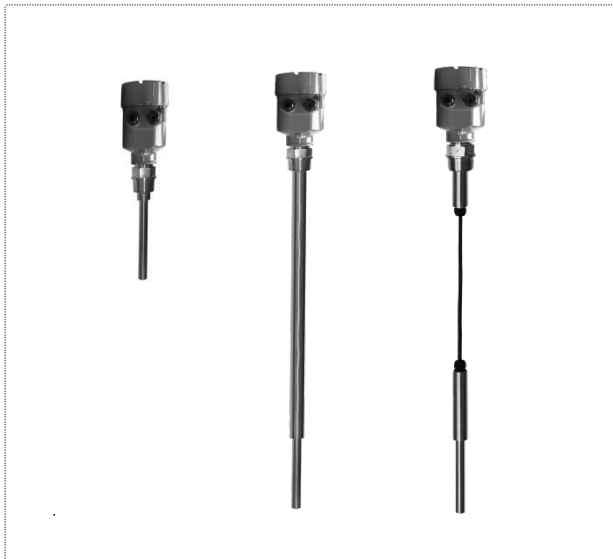

Technical Data of VF(L) / VR

Operating Voltage	Autoadaptation 20-35V DC 30-250V AC
Power consumption	1.5W(Max.)
Isolation voltage	1500V(Min.)
Overvoltage protection	CAT III
Output	Realy DPDT
Output capacity	250VAC, 3A; 30VDC, 1A
Delay time	0-30s adjustable
Switching delay	< 1.0s
Electrical connections	M20X1.5
Ambient temperature	-40 to +70°C
Process temperature	-40°C...250°C (for VR series max. 150°C)
Process pressure	-0.1...1.6 MPa (For VR series 0.1...0.6 MPa)
Process fitting	Threaded 1 1/2" BSPT
Material of probe	SUS 304/316L
Measuring range	4 m (max.)
Insertion length	VF 175 mm VFL 200 ~ 4000 mm VR 1000 ~ 10 000 mm
Frequency	160 Hz
Density of liquid	0.01 g/cm3
Protection class	IP67

Description

VF(L) / VR are level switches for universal use in powders and fine-grained bulk solids. The level switch detects reliably and robust the min. or maxim level. The vibrating rod is ideal for use either in adhesive and abrasive products as well as in bulk solids with very low density.

Features

- Various Process Connections
- No Calibration Required
- Mounting on the top or side of the storage vessel
- Low costs for maintenance through robust design
- Minimum time cost expenditure thanks to simple setup without medium
- Reliable function through product-independent switching point

Installation

Vibrating Rod Level Switches are used to measure levels of dry, SOLID materials via an electrical switching action.

1): max. level 2): min. Level

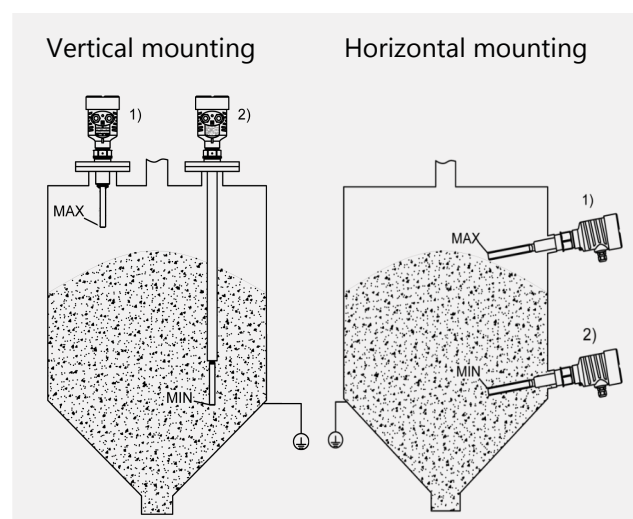

Wiring and Electrical connection

Electrical connection

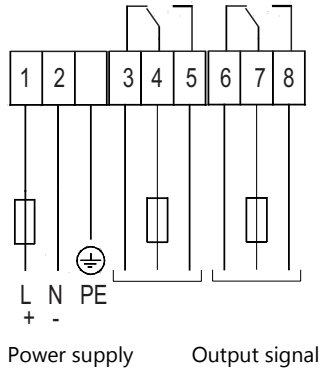

Electrical panel

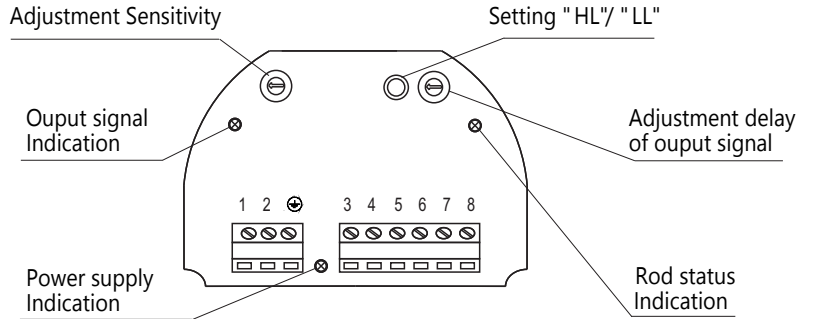

Electrical connection

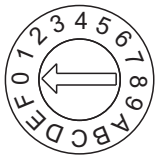

Setting sensitivity class A to F depending bulk density 100..200 g/l.

Output Signal Mode

Mode	Probe no covered in medium	Probe covered in medium
HL	<ul style="list-style-type: none"> ⊗ Ouput signal Indication ⊗ Rod status Indication 	<ul style="list-style-type: none"> ☀ Ouput signal Indication ☀ Rod status Indication
LL	<ul style="list-style-type: none"> ☀ Ouput signal Indication ⊗ Rod status Indication 	<ul style="list-style-type: none"> ⊗ Ouput signal Indication ☀ Rod status Indication

Sensor with thread process:

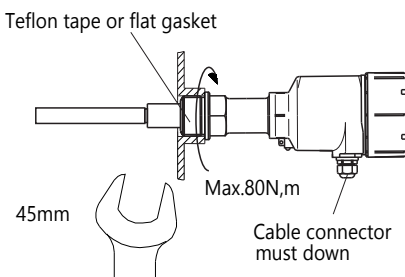

Sensor with flange process:

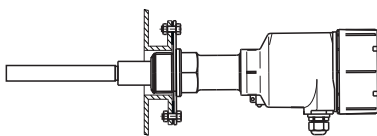

Using gasket to seal

Gasket NBR rubber available to use below 150 °C
Metal or graphite Gasket used more 150 °C process temperature.

Mounting guide

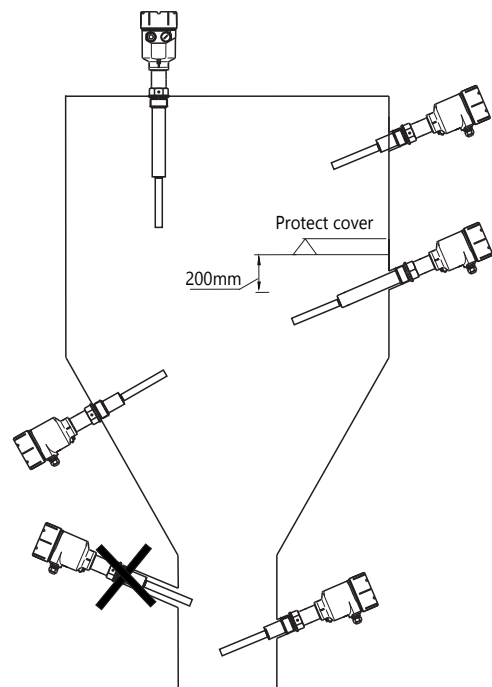

Specification Sheet

How to order

$\frac{VF(L) / VR}{01} - \square_{02} - \square_{03} - \square_{04} - \square_{05} - \square_{06} - \square_{07}$

01) Series of Level Switch

- VF Standard rod
- VFL Extended Rigid Rod
- VR Extended Cable version

02) Material of Housing

- P Aluminum, not singht hole
- PA Aluminum, singht hole
- S SUS304, not singht hole
- SA SUS304, with singht hole

03) Version of Level Switch

- Blank General industrial application
- EX Explosion-proof version

04) Process Temperature

- Blank General industrial -40...+80°C
- T High-Temperature -40...+150°C
- H Ultra High-Temperature -40...+250°C

05) Process Fitting

- B4 1 1/2" BSPT thread
- G4 1 1/2" G thread
- N Thread NPT
- F Flange
- TC Tri-clamp

06) Material of Wetted Parts

- 01 SUS 304
- 02 SUS 316L

07) Insertion Length

- Blank Standard Length
- L500 500mm
- L750 750mm

Dimension, mm

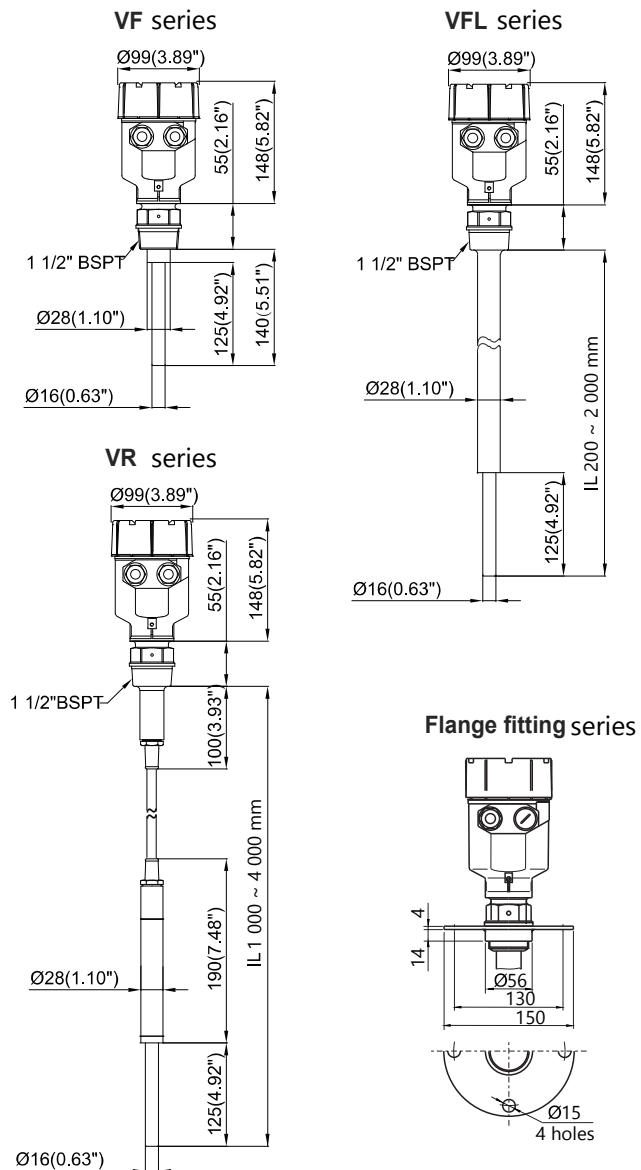

Accessories of process adaptor

Process Adaptor

For the installation of VG extended type of sensors in tanks or pipes

- Pmax - 6 bar
- External thread - 1 1/2" G
- Material - SUS 304
- Code of adaptor - PAG-1 1/2G

